

# Peripheral Pulse Analyzer for Prognosis of Coronary Heart Disease

R.K. Jain, Vineet Sinha, Sadhana A. Mandalik, Gopal Joshi, D. Das, C.K.Pithawa  
Electronics Division, Bhabha Atomic Research Centre,  
Mumbai, India  
rkjain@barc.gov.in

Alaka K. Deshpande  
Department of Medicine, Grant Medical College and JJ  
Hospital, Mumbai, India

**Abstract**— Electronics Division, Bhabha Atomic Research Centre has developed a Peripheral Pulse Analyzer for early detection of coronary heart disease. The instrument employs the principle of impedance plethysmography and measures electrical impedance and its time derivative (representing blood flow) at three consecutive segments on the wrist of the human. In view of our earlier observation that some apparently normal subjects have recorded abnormal impedance plethysmogram from the chest and have suffered heart attack in subsequent 20 years, the peripheral plethysmograms have been analyzed in around 300 subjects. It has shown 8 dominant morphological patterns of the peripheral pulses depending upon their status of health. In cognizance of these observations, a Fourier Transform based method has been developed and incorporated with the instrument to obtain Morphology Index (MI) of the peripheral pulse. The index varies from 0 to 1, the former indicating the poorest and later the complete health. These observations are corroborated by variability spectrum of heart rate and peripheral blood flow. The average index is observed to be around 0.3 in patients with myocardial infarction. Early stages of coronary artery disease bring down the index to around 0.4. Thus it is possible to detect coronary artery disease in early stages.

**Keywords** - Impedance Plethysmograph, Peripheral Pulse Analyser, Pulse Morphology, Morphology Index, Predictive Diagnosis.

## I. INTRODUCTION

Bhabha Atomic Research Centre (BARC) developed 1st model of Impedance Plethysmograph (IPG) in 1978 and installed at Department of Surgery, Seth G.S. Medical College & K.E.M. Hospital and Department of Medicine, Grant Medical College & J.J. Hospital, Mumbai for the assessment of central and peripheral blood flow in the human body. Extensive clinical trials on 103 normal subjects and 10,000 patients with peripheral vascular occlusive diseases at KEM Hospital during 1978 to 1990 and comparison of IPG observations with angiography observations in large number of 500 subjects revealed the sensitivity and specificity of this indigenously developed technique to be 96% and 98% for the diagnosis of peripheral arterial occlusive disease [1] and more than 80% for the diagnosis of deep vein thrombosis [2].

## II. IMPEDANCE CARDIOVASOGRAMS

Impedance Plethysmograms of the thoracic region, commonly known as Impedance Cardiograms (ICG), recorded in control subjects at JJ Hospital have shown different morphological patterns (Fig 1). In a group of 103 subjects, without any demonstrable cardio-vascular disorder, type-A, type-B, type-C and type-D waveforms were recorded in 67, 14,

9 and 13 subjects respectively by Deshpande et al (1990). Estimation of hemodynamic parameters are considered to be reliable in type-A and type-C waveforms as the B-point, marker of the opening of aortic valve, is clearly discernible in the waveform and all measurements (PEP, LVET) can be made with respect to this point. Type B waveform is otherwise recorded in subjects aging more than 40 years, obese or those with systemic hypertension. However computation of LVEF etc. becomes difficult/ambiguous in such cases as B-point is not well defined. Type-D waveform recorded from 13 normal subjects, by no means, can be classified as normal waveform as similar pattern is recorded in patients with tricuspid regurgitation and those with myocardial infarction. Though B point is distinctly seen in this waveform, LVEF obtained from this category is significantly lower. In the absence of clinical correlation, these cases have been regarded as false positives. It is interesting to mention that all the subjects in this group of 13 have suffered heart attack during subsequent 15 years. This suggested predictive diagnostic potential of this technique.

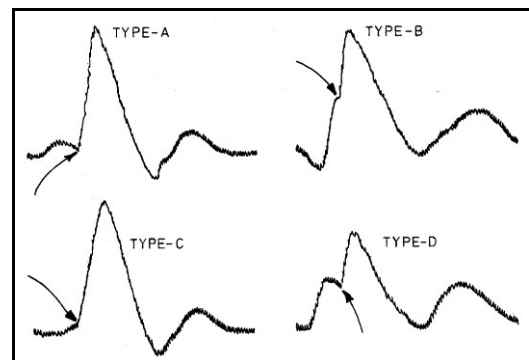

Fig. 1 Variation in the morphology of ICG waveforms in subjects without any demonstrable cardiovascular disorder. B-point, indicated by the arrow, is clearly discernible in type-A and type-C waveforms recorded from 73.8% of the presumably normal subjects. However 26.2% of the subjects have recorded waveforms with morphologies similar to that of type-B or type-D. The waveforms of latter types invariably caused inaccuracy in the computation of hemodynamic parameters.

## III. UPGRADATION IN IMPEDANCE CARDIOVASOGRAMS

The IPG instrument has undergone several renovations during the past 31 years such as microprocessor based impedance plethysmograph, introduction of simple and reliable calibration for  $dZ/dt$  waveform [3], Correction of formula for estimation of peripheral blood flow [4], introduction of normalized  $dZ/dt$  waveform for easy assessment of peripheral blood flow [5], PC based impedance cardiograph system [6] and variability analysis [7].

The Variability Analyzer developed at BARC records peripheral blood flow from the wrist location of the subject for a period of 300 seconds and yields short term variability in heart rate (HRV) and peripheral blood flow (PBFV) which is not available with any other commercial instruments. Preliminary study carried out on 300 subjects at JJ Hospital has shown the effect of several diseases on the variability spectrum of these parameters. Such changes in HRV have already been correlated to peripheral neuropathy in diabetic subjects [8] and other cardio-vascular ailments [9].

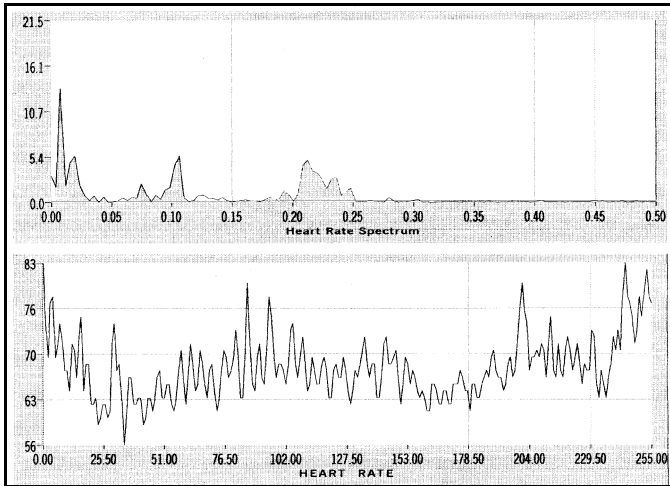

Fig. 2 Typical heart rate fluctuations in time (lower) and frequency domain (upper) in a normal subject.

Figure 2 shows the heart rate variations in time and frequency domain in a control subject. It is difficult to analyze these variations in time domain as several rhythms are simultaneously causing them. However, Power Spectral Density (PSD), obtained by Fast Fourier Transform (FFT) of the same, isolates different rhythms distinctly. There are three distinct peaks observed in the frequency domain centred around 0.008, 0.106 and 0.213 Hz, commonly known as Very Low Frequency (VLF) peak, Low Frequency (LF) peak and High Frequency (HF) peak respectively. Though the origins of these peaks are not clearly understood, it is in general agreed that VLF is contributed by baro-receptor reflex/ renin-angiotensin system; LF is contributed by sympathetic and para-sympathetic nervous system and HF is contributed by vagal slowing part of para-sympathetic system.

While analysing variability Analyzer data, it has been noticed that the morphology of the blood flow pulse varied as a function of time in a given individual and also from individual to individual. It is observed that in a span of 300 seconds an individual has a dominant pattern most of the time with other patterns interposing intermittently. A closer examination of the data in all the 300 subjects has revealed that all the pulse patterns could be classified into 8 basic morphologies as shown in Fig. 3. Top left is the pulse morphology, commonly observed in normal subjects and bottom right is the pulse morphology, commonly observed in patients with severe coronary artery disease.

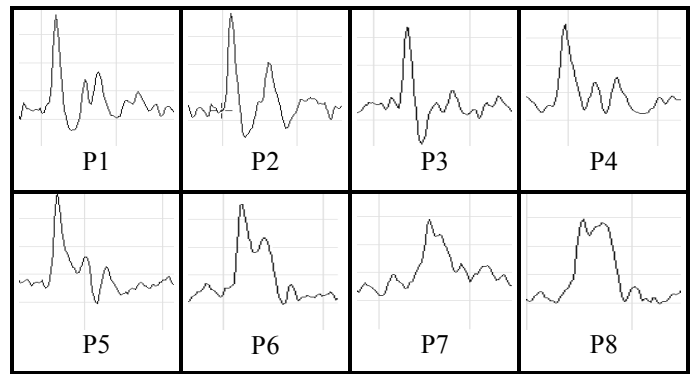

Fig. 3: Eight Basic Morphological Patterns of Peripheral Pulse

In order to assign a numerical value to pulse pattern, named as Morphology Index (MI), K-Factor and Fisher's ratio have been used by others in the past and have met partial success. Closer examination of short term FFT of peripheral pulse has revealed significant difference between spectra of various morphologies. Since data of one cardiac cycle gives poor resolution due to limited number of samples, 511 samples on the left side and 512 samples on the right side of the peak are given as input for short term FFT for higher resolution as shown in Fig. 4. The morphology index (MI) is computed from the FFT data using following formula:

$$MI = \frac{\sum_{i=6}^{i=127} PSD(i)}{\sum_{i=2}^{i=127} PSD(i)}$$

where,  $PSD(i)$  is the sum of squares of real and imaginary Fourier co-efficients as obtained from FFT. The first two co-efficient are ignored as they represent the DC component.

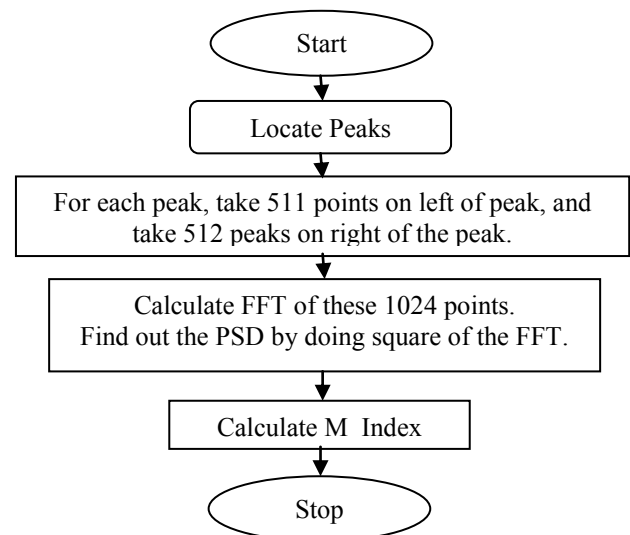

Fig 4 : Flow chart for calculation of MI.

Fig. 5 shows the peripheral pulses and their short term FFT. Only 32 co-efficients are shown for the purpose of clarity. For morphology pattern 1, the high frequency components are dominant with the result the MI is closer to unity. Whereas, for morphology pattern 8, the lower frequency components are dominant with the result that MI is approaching towards Zero.

The other patterns are having values between 0 and 1. Data analysis based on Morphology Index has shown that normal subjects record patterns 1,2 and 3 predominantly with brief interpositions of pattern 4 to 8. Patients suffering from disorders of Lungs, Liver and Heart record patterns 5 to 8 predominantly with brief interpositions of pattern 1 to 4. Patients with beginning of ischemic heart disease show pattern 6 and 7 with occasional interposition of pattern 8, where as those with myocardial infarction show pattern 8 predominantly provided the patient is not on heavy dose of aspirin or beta blockers.

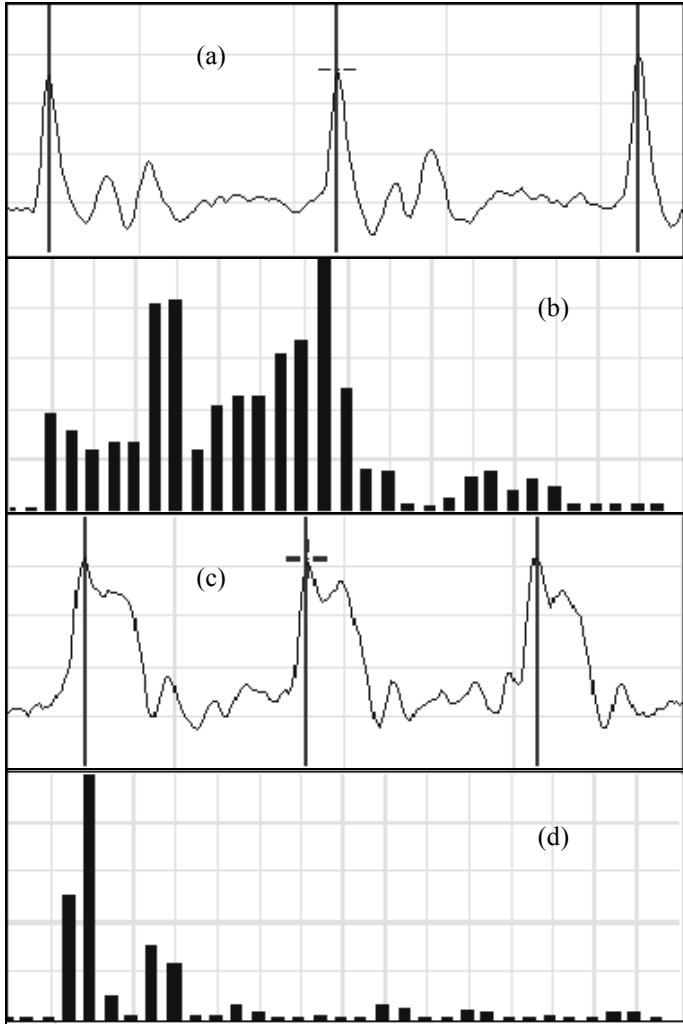

Fig. 5 shows the peripheral pulse recorded from a normal subject (a) and a patient with severe coronary artery disease (c). The short term FFT is given in (b) and (d) respectively

#### IV. PERIPHERAL PULSE ANALYZER

In view of above, an instrument named as Peripheral Pulse Analyzer, incorporating all the features described above, has been developed at Electronics Division BARC. It comprises a sine-wave oscillator, voltage to current converter, three sensing amplifiers along with analog processing circuits, a low power micro-controller and a Bluetooth controller communicating with a personal computer as shown in Figure 6. A fixed amplitude sinusoidal current (2 mA) is passed through the upper extremity by applying carrier electrodes C1 and C2

around elbow and palm. The voltage developed along the current path is sensed from three locations at the wrist with the help of sensing electrodes S1-S4, with S1 proximal to elbow and S4 to the palm. The inter-electrode distance between S1 to S4 is kept around 2 cm. The voltage differences between S1 and S2; S2 and S3; and S3 and S4 are amplified with the help of sensing amplifiers (1) to (3) respectively. These locations on the wrist correspond to Vata, Pitta and Kapha locations of Ayurvedic System of Medicine. The amplified signals are further processed to yield impedance of the segment ( $Z1$  to  $Z3$ ), change in impedance as a function of impedance ( $\Delta Z1$  to  $\Delta Z3$ ) and first time derivative of impedance ( $dZ1/dt$  to  $dZ3/dt$ ) representing body composition, blood volume change and blood flow in the respective segment respectively. These signals are connected to ADC inputs of the micro-controller as shown in the figure. These signals are acquired at a rate of 500 samples per second and communicated to personal computer through Bluetooth controller for further processing and analysis. Figure 7 shows the photograph of the instrument along with personal computer.

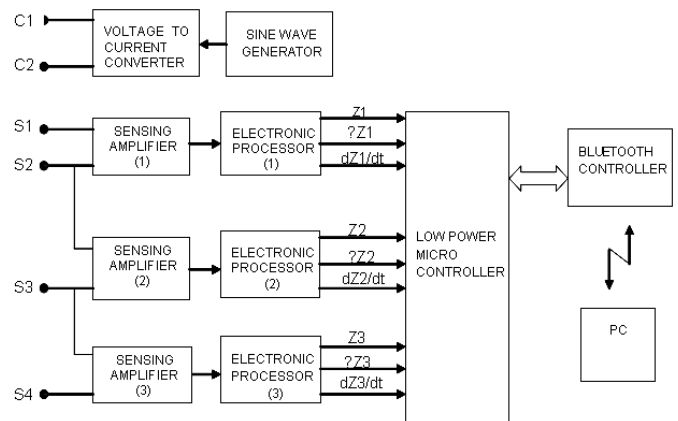

Fig 6: shows the schematic diagram of the Peripheral Pulse Analyzer developed at Electronics Division BARC.



Figure 7: Peripheral Pulse Analyzer in action

The firmware includes acquisition of all the user selected signals at selectable rate and sending to PC through Bluetooth controller. The application software has two parts; acquisition and processing, described elsewhere [10]. During acquisition, after entering the personal data and basic settings for the subject, click on AQUIRE button starts data acquisition till the same button is re-clicked or 275 seconds have elapsed,

whichever is earlier. At the end of acquisition, the data is saved in the prescribed file format. Also the file can be converted to ASCII format and saved for processing on other software packages. For processing the file, the patient data is loaded by clicking on LOAD, signals are selected for processing and SELECTION PANEL is clicked. Cursor is placed on third systolic peak in dZ3 (dZ/dt is abbreviated as dZ) and LOCATE PEAK is clicked. This automatically highlights all the systolic peaks in the signal. Any discrepancy in peak selection shows up on the 4<sup>th</sup> graph (from top), labelled as HR\_dZ3 in the panel, which can be manually edited by using INSERT, DELETE, SHIFT LEFT and SHIFT RIGHT buttons. A click on MARK PEAKS plots all the graphs below and those on the right showing variations in blood flow, morphology index and pulse travel time in time domain for all the dZ (dZ/dt abbreviated as dZ) signals as shown in Figure 10. These are labelled as 'BFV\_dZ1, BFV\_dZ2, BFV\_dZ3, MI\_dZ1, MI\_dZ2, MI\_dZ3, dZ3-dZ1, dZ1-dZ2 and dZ2-dZ3' respectively. Any spurious spike is manually edited using the above described buttons. The selected peak information is then saved in the file.

As can be seen from the figure MI\_dZ3 shows wide variation in the morphology of the pulse ranging from 0.30 to 0.89. The short term FFT shown in the graph by the side of HR\_dZ3 graph is for the peripheral pulse for MI equal to 0.89. The corresponding pulse pattern can be seen in the graph labelled dZ3, which resembles pattern P1. One can also get the average morphology index for the subject by quitting this panel and going to DISPLAY panel, where the variability is shown in frequency domain.

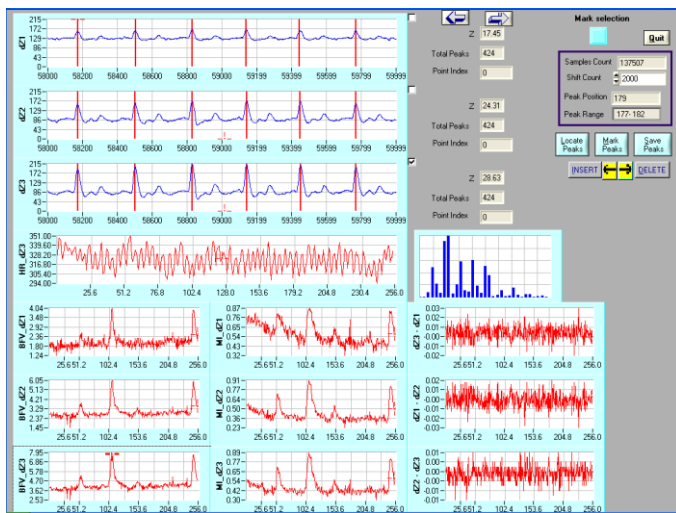

Fig 10: The selection panel during processing of the data, displaying variability of various parameters in time domain and short term Fourier Transform of a particular data segment.

The instrument has been used for screening nearly 100 subjects suffering from various disorders. Consistently those suffering from coronary heart disease have recorded patterns P6 to P8, with average morphology index ranging from 0.3 to 0.45. Multi-centric trials are in progress at Grant Medical College & J.J. Hospital, Mumbai; Ayurved Hitaishani Trust, Samshodhan Kendra, Thane; Father Muller Homeopathic Medical College, Mangalore; Father Muller Medical College, Mangalore; and Arya Vaidya Sala, Kotakkal. PPA Instrument is being validated by different streams of Medical Sciences under different BRNS projects. In the field of Ayurveda and Allopathy PPA is being validated for finding out Prukruti of the person. In case of Homeopathy, it is being used for establishing the effect of material less homeopathic medicines. Results obtained so far are encouraging.

#### ACKNOWLEDGMENT

The authors acknowledge contribution of Dr. G.D. Jindal, Ex. BARC in seeding the concept of disease characterization using pulse morphology and help from Smt. Gouri V. Sawant & Shri Ashok D. Kamble in data collection and processing.

#### REFERENCES:

- [1] Jindal GD, Nerurkar SN, Pednekar SA, Babu JP, Kelkar MD, Deshpande AK and Parulkar GB, Diagnosis of peripheral arterial occlusive diseases using impedance plethysmography, J. Postgrad. Med. Vol. 36, p.147, 1990.
- [2] Jindal GD, Pedhnekar SA, Nerurkar SN, Masand KL, Gupta DK, Deshmukh HL, Babu JP and Parulkar GB, Diagnosis of venous disorders using impedance plethysmography, J. Postgrad. Med. Vol. 36, p.158, 1990.
- [3] Jindal GD, Babu JP, Calibration of dZ/dt in impedance plethysmography, Med. Biol. Engg. & Comput. Vol. 23, p. 279, 1985.
- [4] Jindal GD, Nerurkar SN, Pednekar SA, Babu JP, Kelkar MD and Deshpande AK, Corrected formula for estimating peripheral blood flow by impedance plethysmography, Med. Biol. Engg. Comput. Vol. 32, p.625, 1994.
- [5] Jagruti C, Chaugule N, Ananthkrishnan TS, Prakash Babu J and Jindal GD, Normalized DZ/DT waveform for easy assessment of peripheral blood flow, Proc. SBME-NM 2000, p.67, 2000.
- [6] Jindal GD, Ananthkrishnan TS, Kataria SK and Deshpande AK, An Introduction to Impedance Cardiovasography, External Report, BARC/2001/E/003, 2001.
- [7] Jindal GD, Ananthkrishnan TS, Mandlik SA, Sinha V, Jain RK, Kini AR, Nair MA, Kataria SK, Mahajan UA and Deshpande AK, Medical Analyzer for the study of physiological variability and disease characterization, External Report, BARC/2003/E/012.
- [8] Bianchi A, Bontempi B, Cerutti S, Gianoglio P, Comi G and Natali Sora MG, Spectral analysis of heart rate variability signal and respiration in diabetic subjects, Med. and Biol. Eng. and Comput., Vol. 28, pp 205-211, 1990.
- [9] Marek Malik, Clinical Guide to Cardiac Autonomic Tests, Kluwer Academic Publishers, 1998.
- [10] Jindal GD, Deepak KK and Jain RK, A Handbook on Physiological Variability, Proceedings, Theme Meeting on Advanced Applications of Physiological Variability – 2010, BARC, Mumbai.